



SPECIFICATIONS

- CONTACT RATING:** AC 125V 6A, AC 250V 3A, DC 30V 3A
- MECHANICAL LIFE:** 200,000 make-and-break cycles DC 10V & 0.1mA.
- CONTACT RESISTANCE:** 10mΩmax.
- INSULATION RESISTANCE:** 500V 500MΩmin.
- DIELECTRIC STRENGTH:** 1,000 V RMS@sea level.
- OPERATING TEMPERATURE:** -30°C to 85°C.
- WATER-RESISTANCE:** 100 make-and-break cycles min at 10cm depth

MATERIALS

- CASE:** Diallyl phthalate (DAP) (UL94v-0).
- ACTUATOR:** Brass, chrome plated.
- BUSHING:** Brass, nickel plated.
- HOUSING:** Stainless Steel.
- SWITCH SUPPORT:** Brass, tin plated.
- TERMINAL/CONTACT:** Silver or gold plated. (See Page 25)

HOW TO ORDER

MODEL NO. ACTUATOR BUSHING TERMINATIONS CONTACT MATERIAL SEAL ROHS SOLDERING

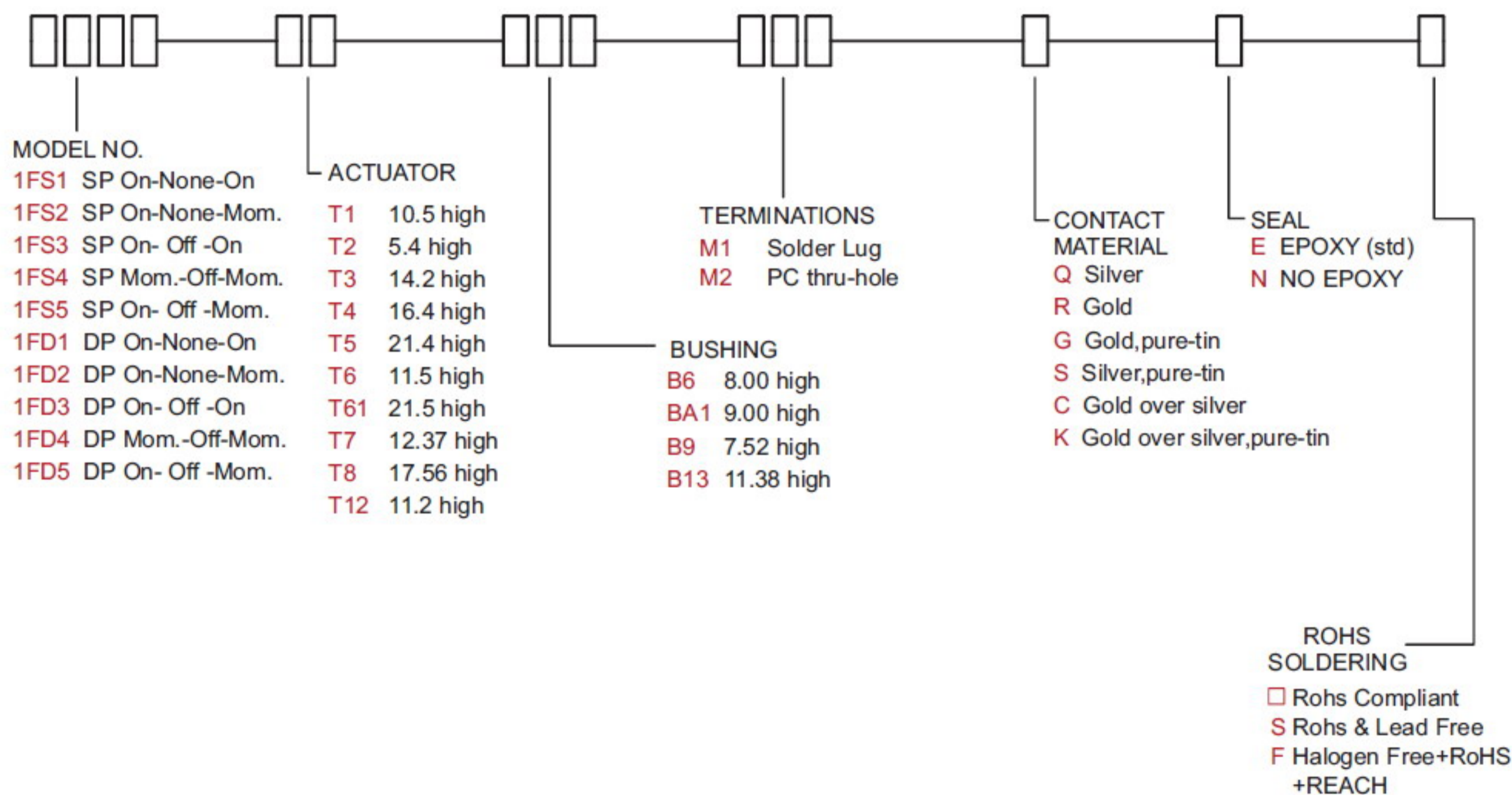

SWITCH FUNCTION

NO. POLES	MODEL NO.	SWITCH FUNCTION			CONNECTED TERMINALS / SCHEMATIC				
		POS.1	POS.2	POS.3	POS.1	POS.2	POS.3		
SP	1FS1	ON	NONE	ON	2-3	N/A	2-1		
	1FS2	ON	NONE	MOM					
	1FS3	ON	OFF	ON					
	1FS4	MOM	OFF	MOM					
	1FS5	ON	OFF	MOM					
DP	1FD1	ON	NONE	ON	2-3,5-6	N/A	2-1,5-4		
	1FD2	ON	NONE	MOM					
	1FD3	ON	OFF	ON					
	1FD4	MOM	OFF	MOM					
	1FD5	ON	OFF	MOM					

MOM=MOMENTARY

ACTUATOR OPTIONS

T1 STD

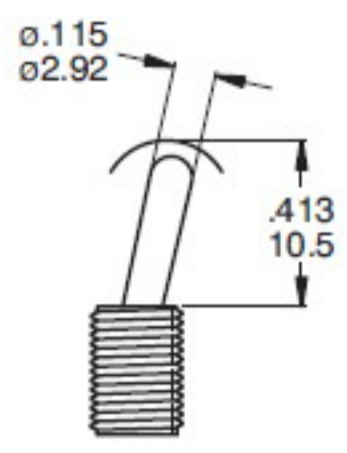

T2

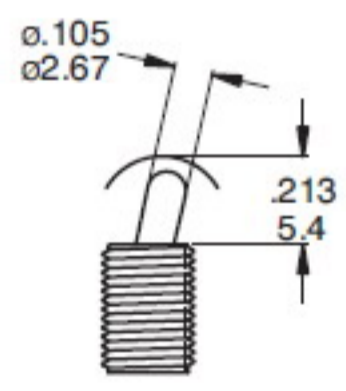

T3

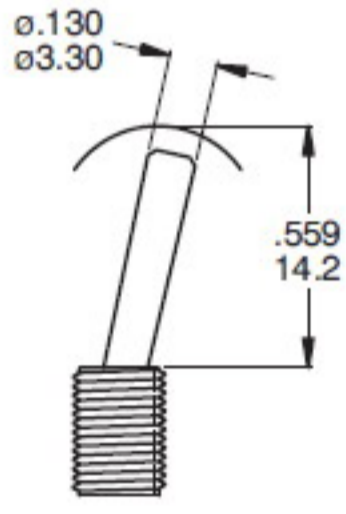

T4

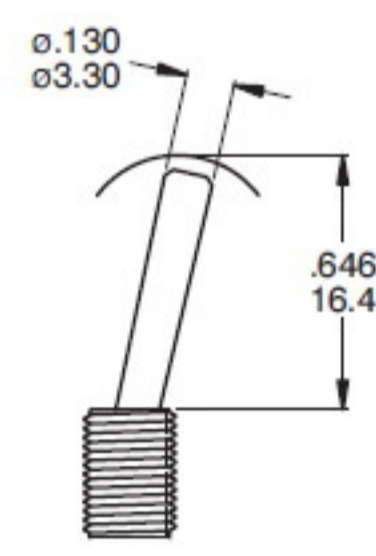

T5

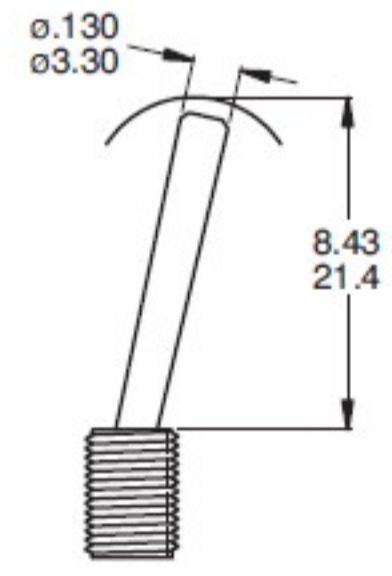

T6 FLATTED WITH ANTIROTATION

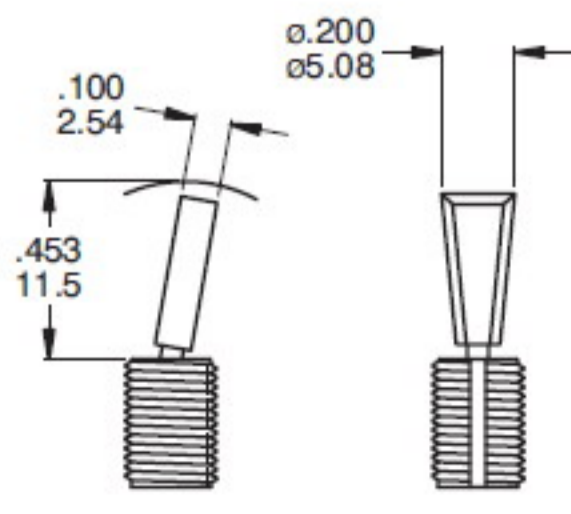

T61

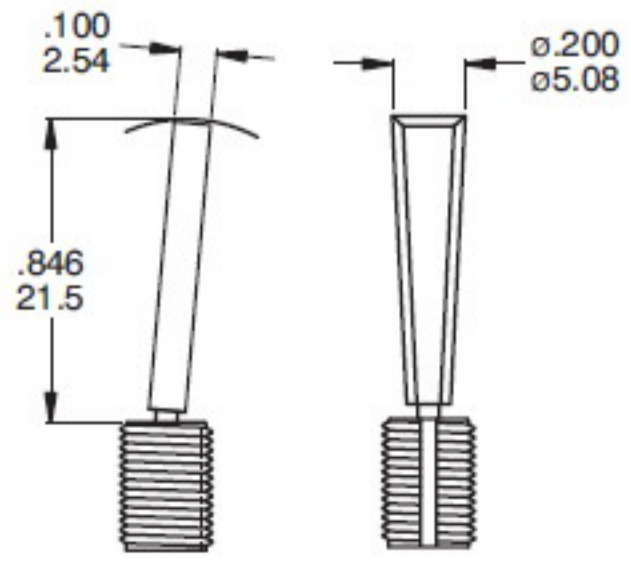

T7

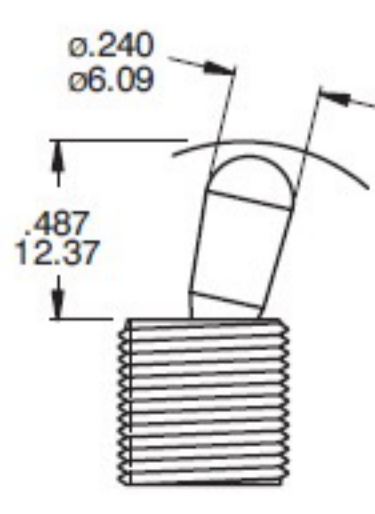

T8

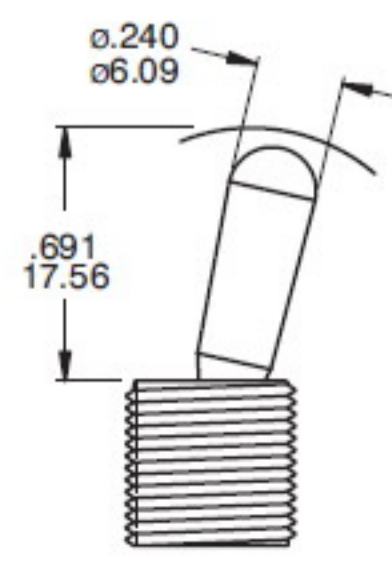

T12

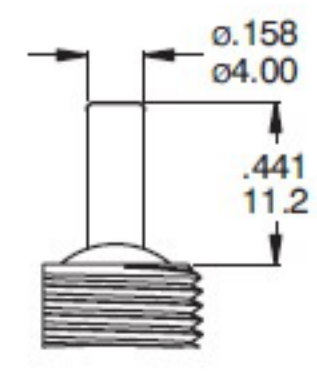

T6,T6-1 use with B6 bushing only

T7,T8 use with B13 bushing only

T12 use with BA1 bushing only

BUSHING OPTIONS

B6 HIGH TORQUE

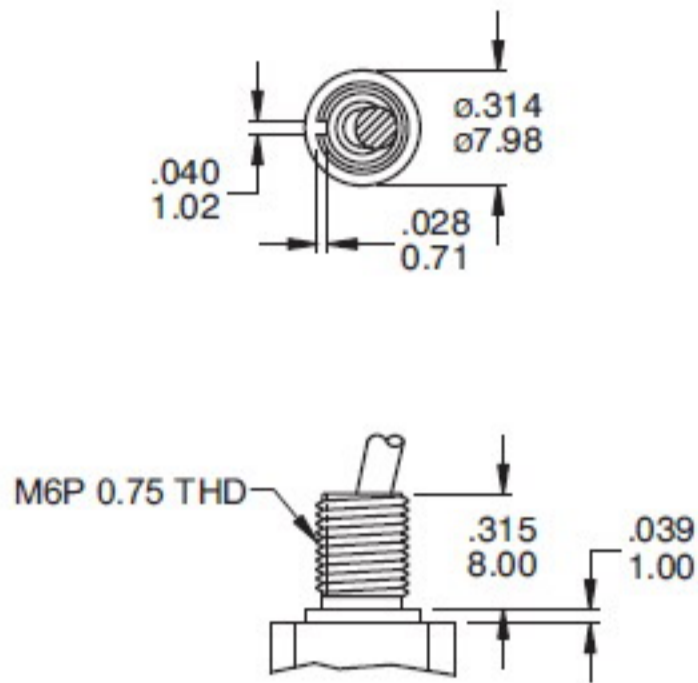

BA1 SPLASH PROOF

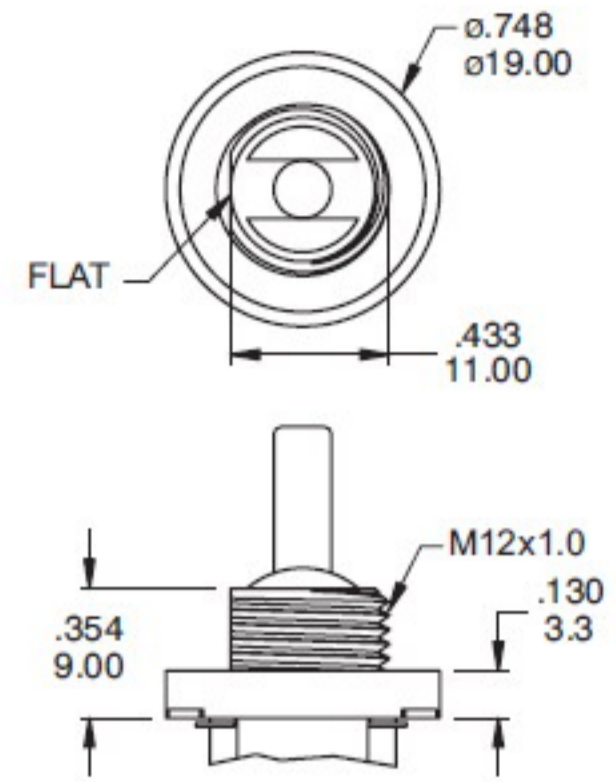

Use with T12 actuators only
BA1 Bear Strength from top of actuator up to 10kg aside up to 15kg

B9 SPLASH PROOF

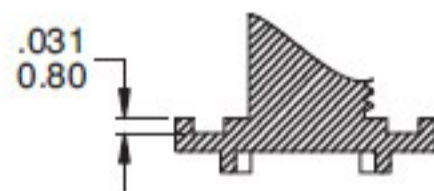
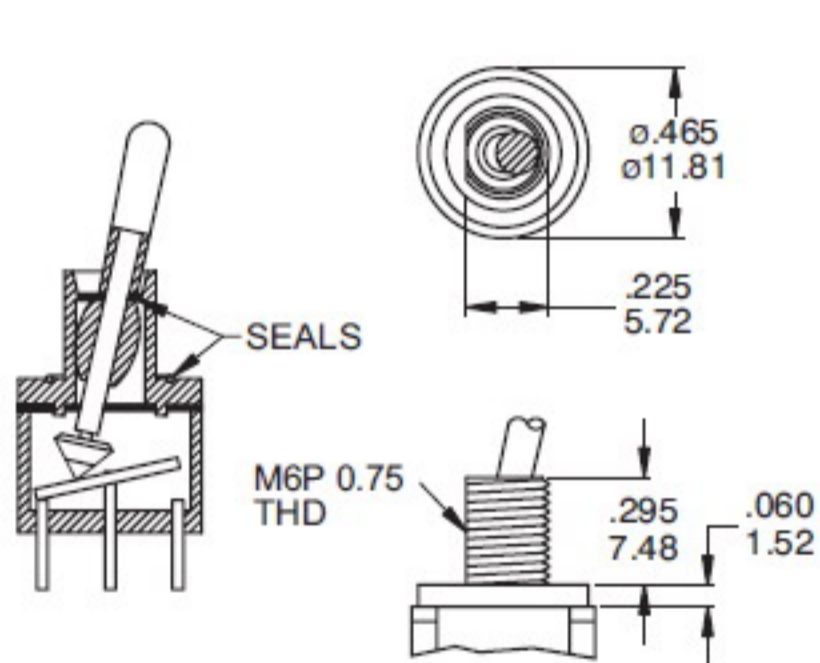

CP-1TEB

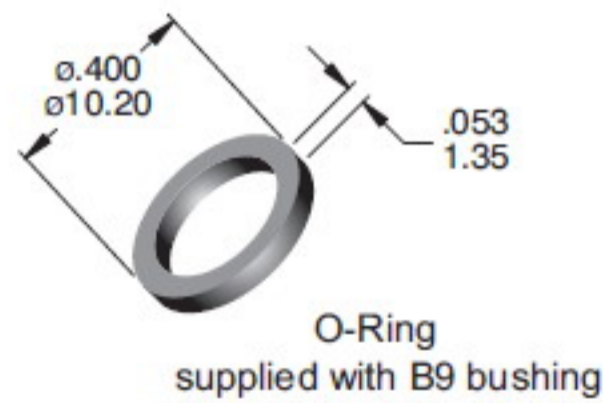

B13

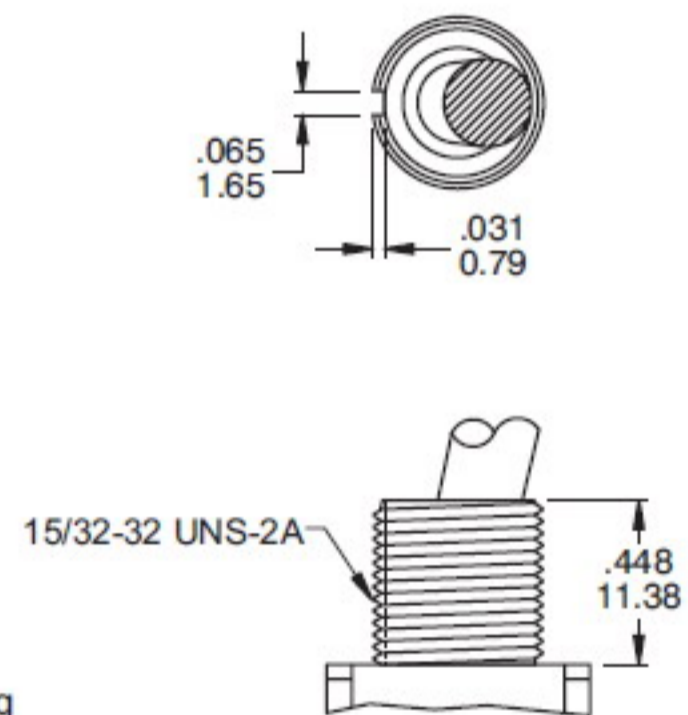

TERMINATION OPTIONS

M1 SOLDER LUG

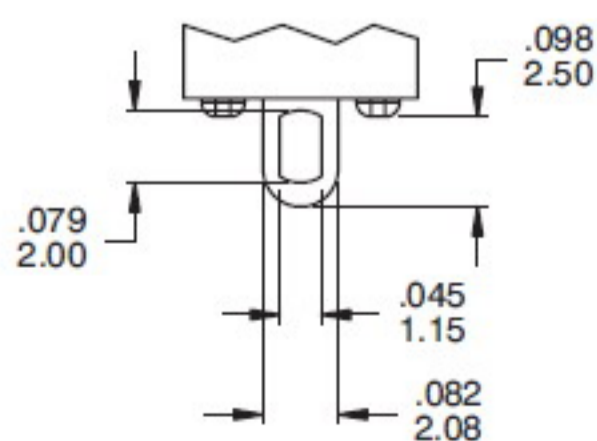

M2 PC THRU - HOLE

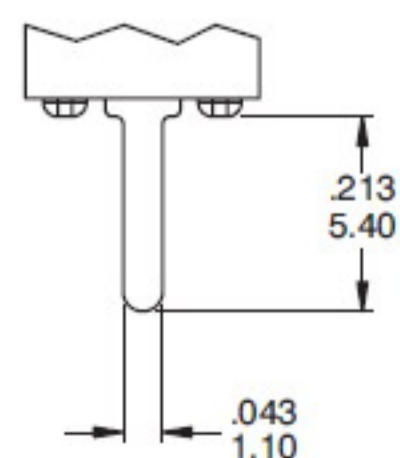

POLE OPTIONS

SPDT

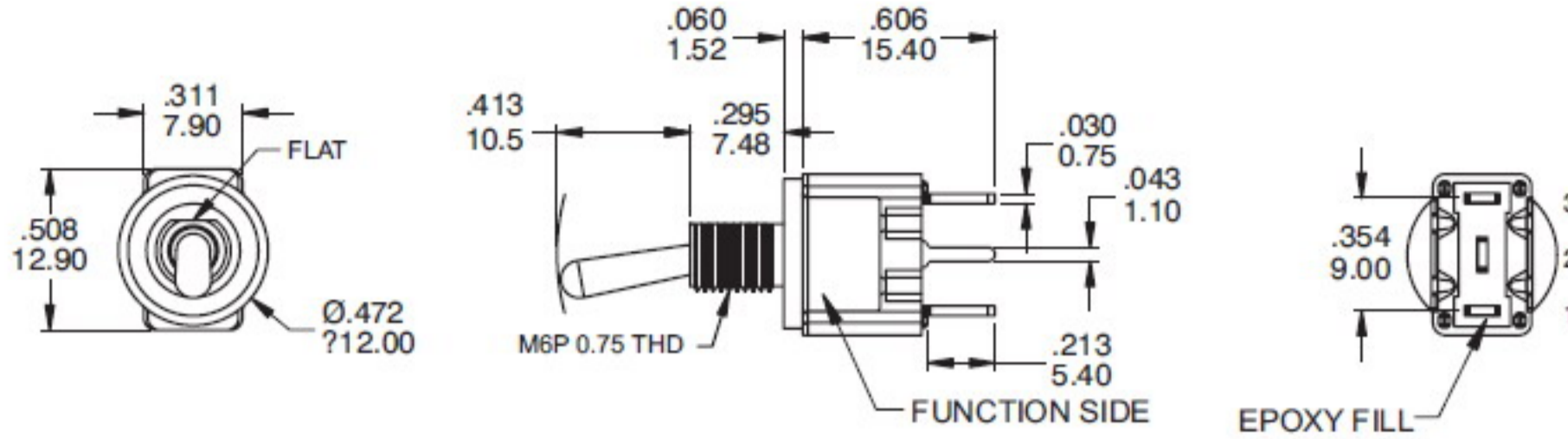

Part No. Shown : 1FS1T1B9M2QES

DPDT

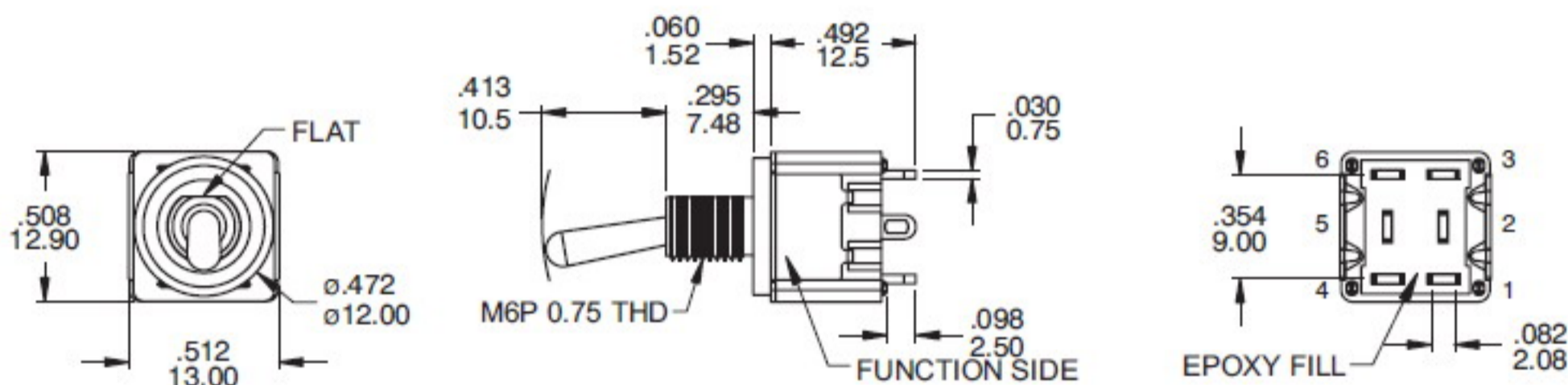

Part No. Shown : 1FD1T1B9M1QES

SPDT

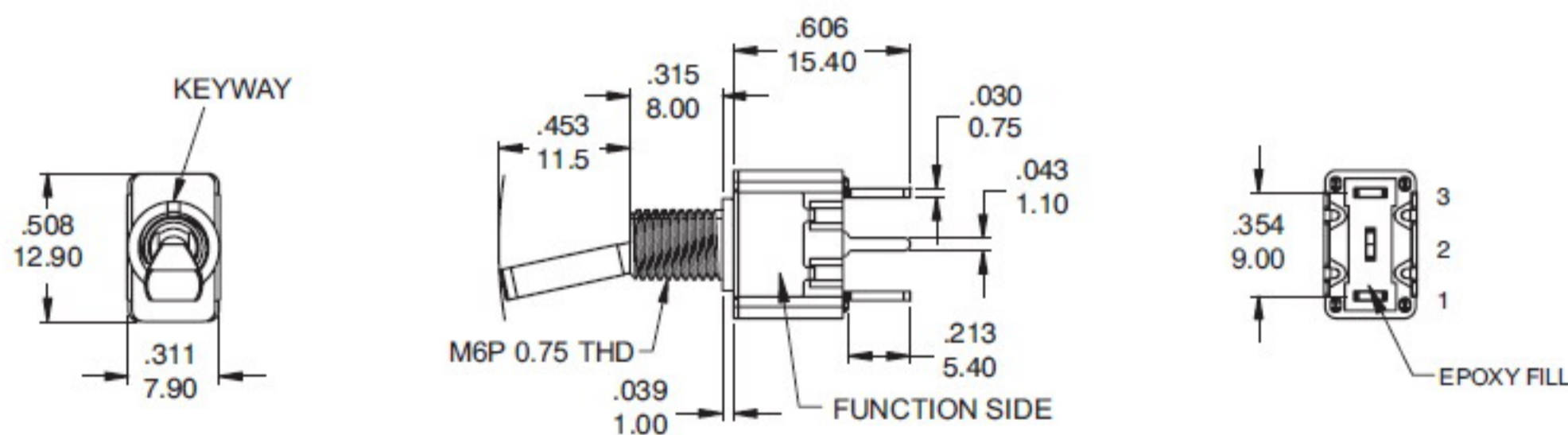

Part No. Shown : 1FS1T6B6M2QES

DPDT

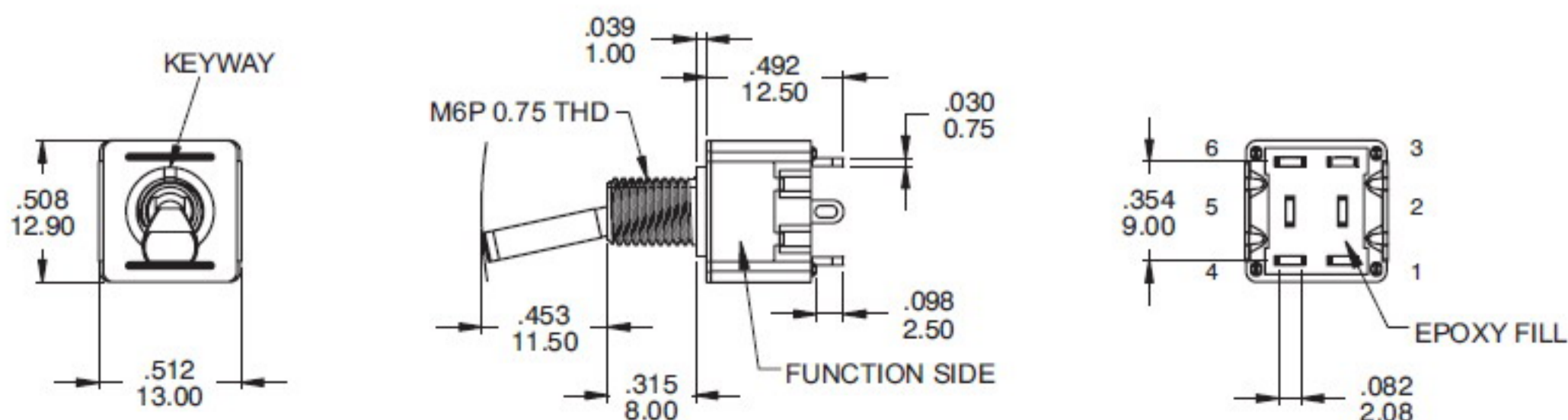

Part No. Shown : 1FD1T6B6M1QES

SPDT

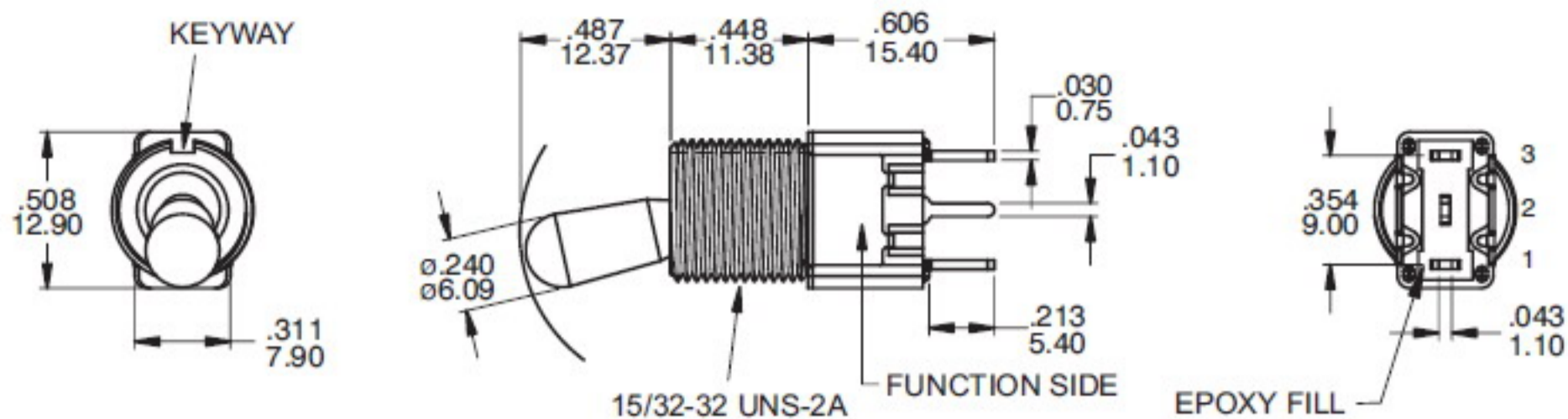

Part No. Shown : 1FS1T7B13M2QES

DPDT

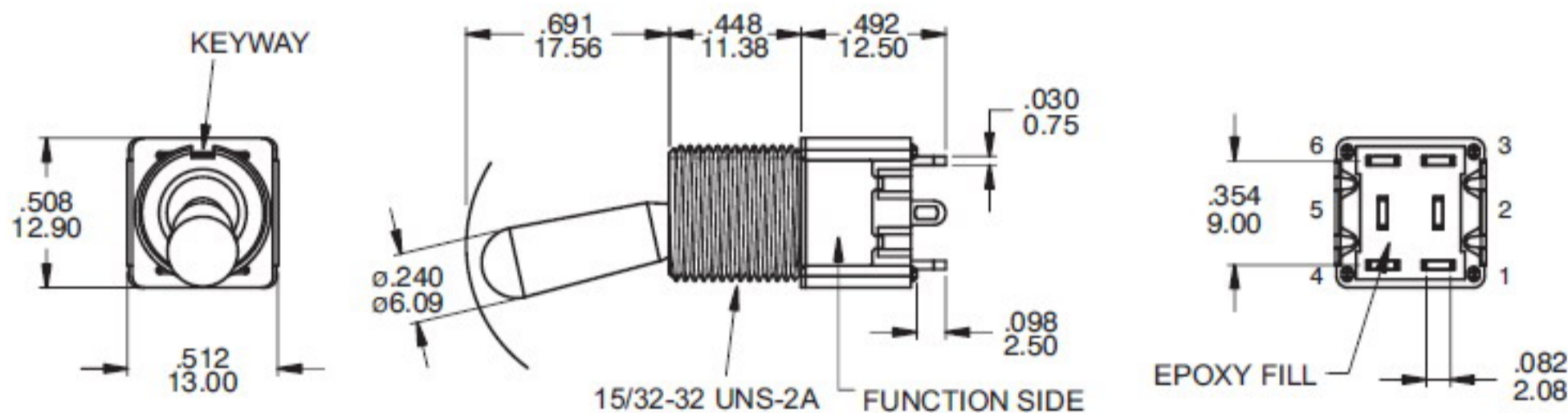

Part No. Shown : 1FD1T8B13M1QES

SPDT

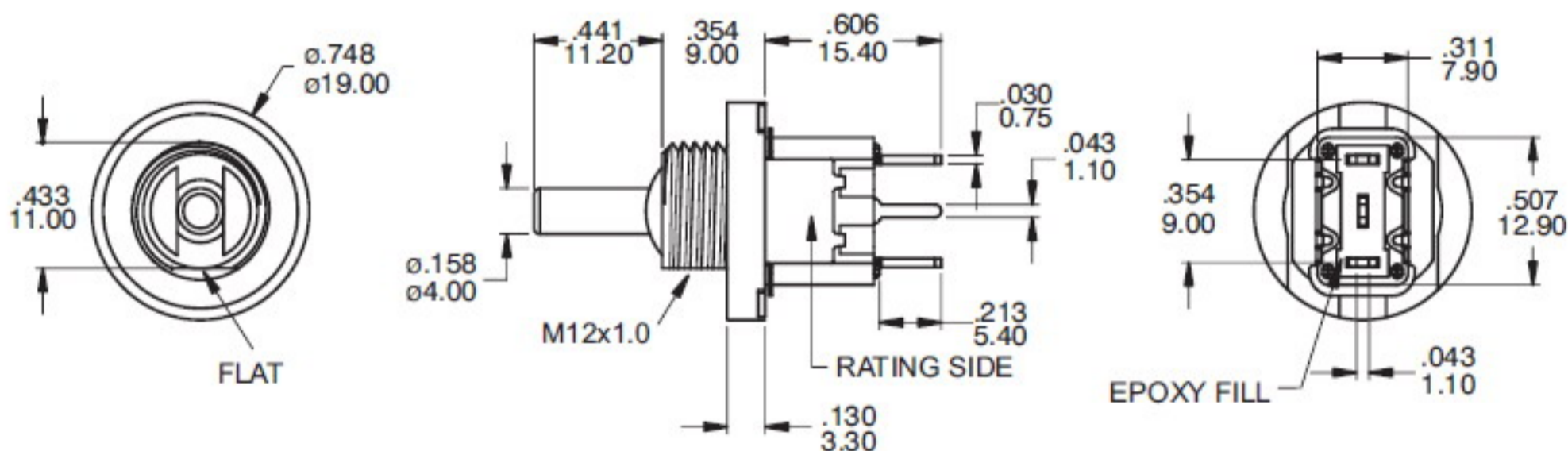

Part No. Shown : 1FS1T12BA1M2QES

DPDT

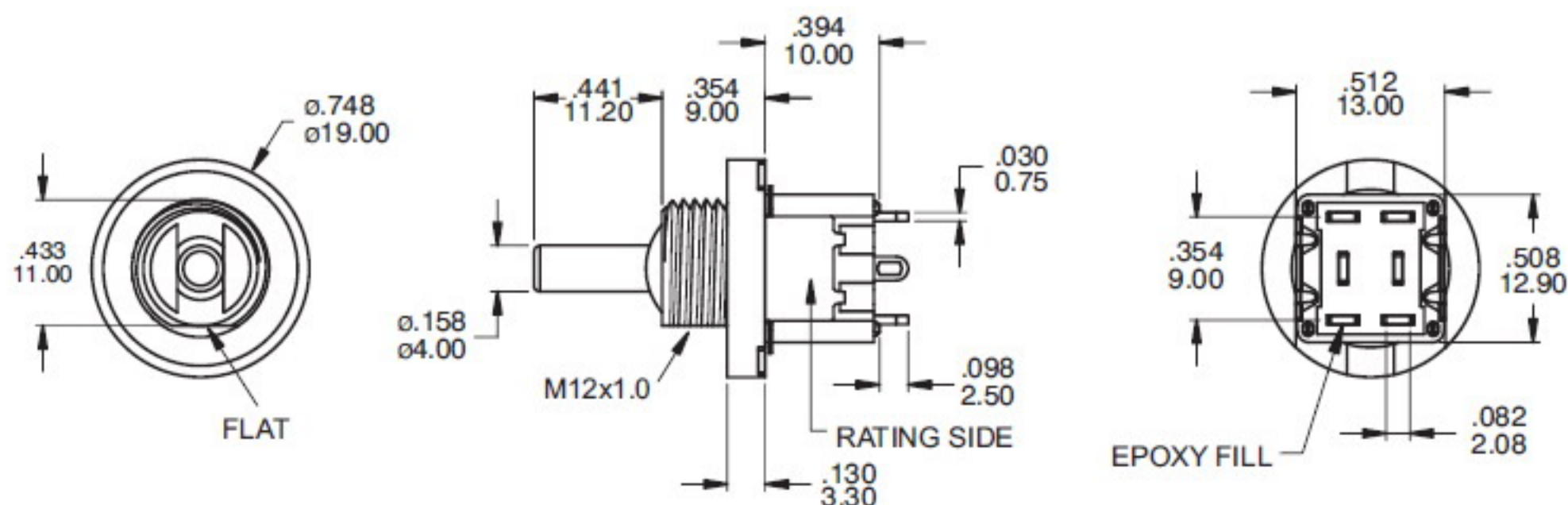

Part No. Shown : 1FD1T12BA1M1QES

CONTACT MATERIAL OPTIONS

	CONTACT MATERIAL	TERMINAL PLATING	RATINGS
Q	Silver	Q = Silver	6 Amps with resistant load @ 125VAC or 28VDC 3 Amps with resistant load @ 250VA
S		S = Silver,pure - tin	
C	Gold over Silver	C = Gold over silver	
K		K = Gold over silver,pure - tin	
R	Gold	R = Gold	0.4 Volt - Amps (VA) max. @ 20V max. (AC or DC)
G		G = Gold,pure - tin	



SOLDERING PROCESSES

MANUAL SOLDERING : Use soldering iron of 30 watts, controlled st 350°C approximately 5 seconds while applying solder.

WAVE SOLDERING : Recommended Soldering Temperature : 260 ± 5°C
Duration of Solder Immersion : 5 ± 1 seconds
(PCB is 1.6mm in thickness)

SOLDERING : Vapor phase

