

## 1 Description

This product specification is applied to the Humidity Sensor Type HCZ – D5. The terminal electrode material uses Lead free solder (Sn/Ag/Cu ). This product is conformity with RoHS directive which means that lead, cadmium, mercury, hexavalent chromium and specific bromine-based flame retardants have not been used.

## 2 Applications

The applications of the component are used in relative humidity measurement, control and display. There are many end products can be used. For example air conditioner, humidifier, dehumidifier, hygrometer, recorder, transmitter...etc.

## 3 Model no.

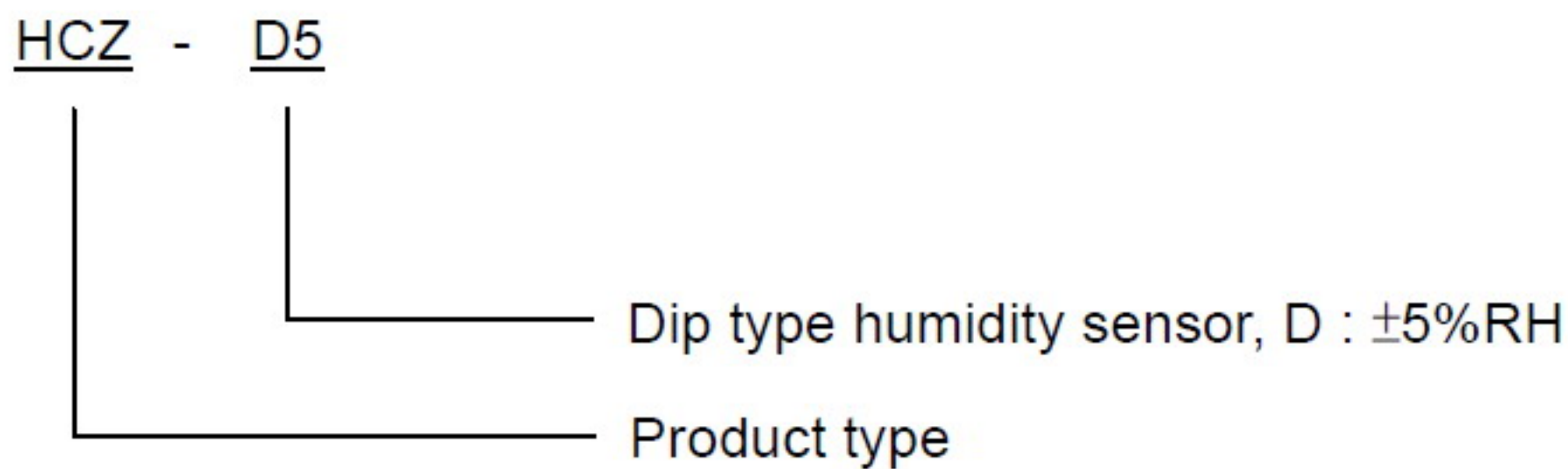

## 4 Configuration & main parts

### 4.1 Configuration

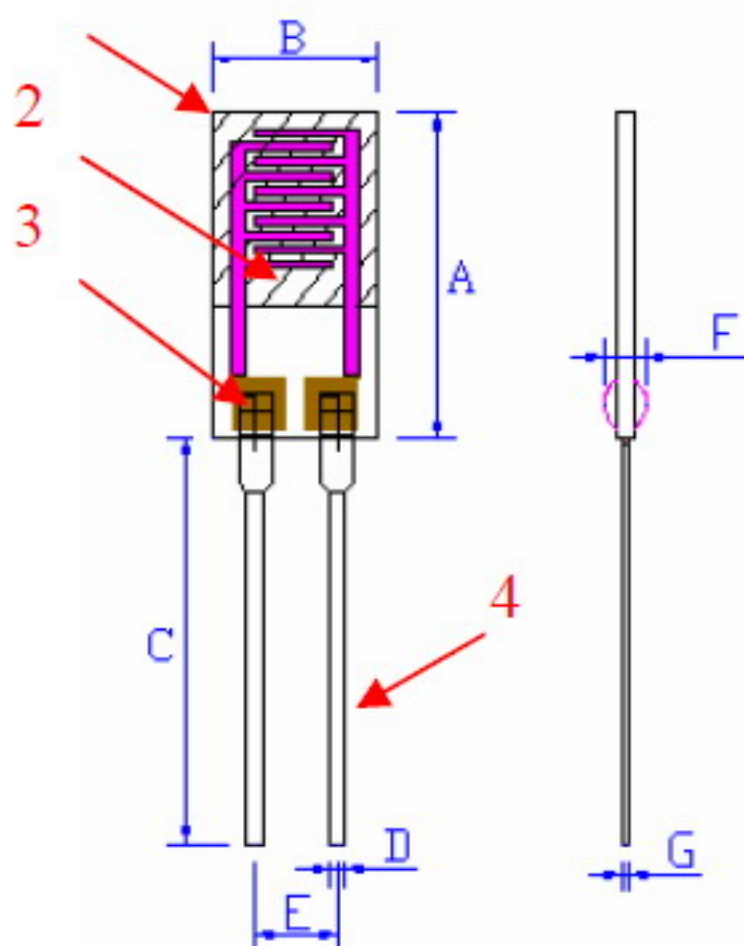

Symbol	Specification
A	$10 \pm 0.2$
B	$5 \pm 0.2$
C	$15 \pm 2$
D	0.5
E	2.54
F	1.8max
G	0.25

Units : mm



# PRODUCT SPECIFICATIONS

HCZ-D5

## 4.2 Main parts :

No.	Parts	Reference
1	Sensor case	ABS
2	Substrate	Alumina
3	Sensing material	Polymer
4	Electrode	Ag/Carbon
5	Lead frame	Phosphor bronze

## 5 Electrical characteristics :

### 5.1 General Characteristics :

	Units	Min.	Typ.	Max.
Rated voltage	Vrms	-	-	1
Rated power	mA	-	-	0.2
Operating frequency range	kHz	0.5	1	2
Operating temperature range	°C	0	-	60
Operating humidity range	%RH	-	-	90
Impedance range at 60%RH and 25°C**	kΩ	19.8	-	50.2
Humidity accuracy	%RH	-5	-	+5
Hysteresis (40%RH~80%RH)	%RH	-	-	2
Temperature dependence(reference)	%RH/°C	-	0.3	-

\*\* Measurement by LCR meter at 1KHz, 1 Vrms(sine wave)

### 5.2 Relative humidity - Impedance – 25°C, 1kHz, 1 Vrms(sine wave)

%RH	20	30	40	50	60	70	80	90
Normal value (kΩ)	6,300	1,400	310	87	31	11.8	4.8	2.0

### 5.3 Relative humidity - Impedance curve is shown in page 5



# PRODUCT SPECIFICATIONS

HCZ-D5

## 6 Mechanical characteristics :

No.	Item	Description	Criteria*
6.1	Shock resistance	Drop down 3 times@75cm	No abnormal appearance & electrical properties
6.2	Vibration resistance	2 hours each in the directions of X-Y-Z, at the frequency of 10-55Hz, and amplitude of 1.5mm	No abnormal appearance & electrical properties
6.3	Resistance to soldering heat	The lead terminal shall be Immersed by 3 mm from the substrate for 3 seconds in solder bath of 260±5°C	No abnormal appearance & electrical properties
6.4	Strength of terminations	500g@10 seconds in the axial direction of lead terminal	Secured

## 7 Reliability :

No.	Item	Description	Criteria*
7.1	Heat resistance	1000 hours@70°C	< ±5%RH
7.2	Cool resistance	1000 hours@-30°C	< ±5%RH
7.3	Humidity resistance	1000 hours@40°C, 90%RH	< ±5%RH
7.4	Humidity cycle	Repeat 500 cycles One cycle: 30 minutes@25°C, <30%RH 30 minutes@25°C, >90%RH	< ±5%RH
7.5	Temperature cycle	Repeat 100 cycles Each cycle: 30 minutes@-30°C 30 minutes@85°C	< ±5%RH
7.6	Voltage resistance	3000 hours@1KHz, 1Vrms	< ±5%RH

\* The criteria test that the sensors finish the description process after 2 hours under normal temperature and humidity. The test condition is fixed at 25°C, 60%RH by LCR meter at 1KHz, 1 Vrms(sine wave)



## 8 Packaging :

### 8.1 HCZ-D5

8.1.1 245 pieces were layed in tray, and 5 trays envelope in bag.

8.1.2 10,000 pieces packed in a shipping carton box (430\*360\*390mm).

8.1.3 In case of fractional package, the above tray and carton box may not be used.

### 8.2 Caution remarks on operation :

8.2.1 To avoid direct application of DC voltage on humidity sensor.

8.2.2 To protect sensor from dewfall and drenching.

8.2.3 To avoid any operation of humidity sensors in the following environmental ambient.

8.2.3.1 Salt

8.2.3.2 Inorganic gas – Sulfide dioxide, Chlorine, Ammonia etc.

8.2.3.3 Organic gas – Alcoholic, Glycols, Aldehydes etc.

8.2.4 Recommended storage condition

Temperature range 10~40°C

Humidity range 90%RH or less

8.2.5 Do not store humidity sensors long period of time in an over 60%RH ambient due to some occasion of degradation on sensor housing case.

## REFERENCES

- Relative humidity - Impedance curve – measured at 1kHz, 1 Vrms(sine wave)

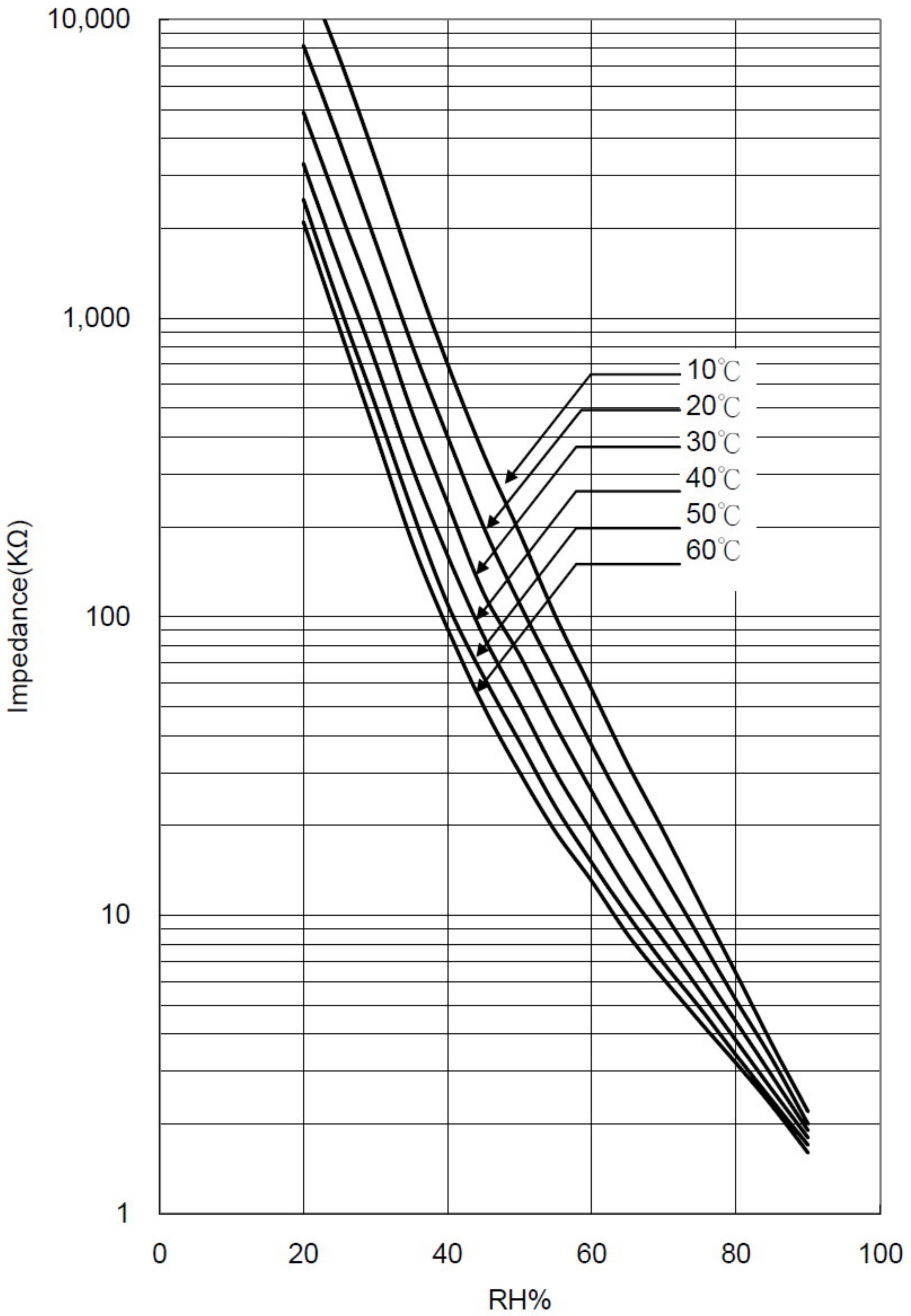



# PRODUCT SPECIFICATIONS

HCZ-D5

Impedance -- %RH VS. Temperature

Unit:KΩ

RH%	5°C	10°C	15°C	20°C	25°C	30°C	35°C	40°C	45°C	50°C	55°C	60°C
20		15,000	11,000	8,200	6,300	4,900	4,000	3,300	2,800	2,500	2,200	2,100
25	10,000	7,400	5,300	3,900	3,000	2,300	1,800	1,500	1,300	1,100	1,000	920
30	4,800	3,400	2,400	1,800	1,400	1,100	870	710	600	510	450	410
35	2,100	1,500	1,100	820	630	490	390	320	270	230	200	180
40	980	700	520	400	310	240	190	160	130	110	100	91
45	480	350	260	200	160	120	100	86	73	63	55	50
50	250	190	140	110	87	74	61	51	44	38	34	30
55	130	100	80	64	49	43	36	30	26	23	21	19
60	73	57	46	37	31	26	22	19	17	15	14	13
65	41	32	27	22	19	16	14	12	11	10	9.2	8.6
70	23	19	16	14	11.8	10.2	9.1	8.2	7.5	6.9	6.5	6.1
75	13	11	9.5	8.4	7.5	6.7	6.1	5.6	5.2	4.9	4.6	4.4
80	7.2	6.4	5.8	5.2	4.8	4.4	4.1	3.8	3.6	3.4	3.3	3.2
85	4.0	3.7	3.5	3.3	3.0	2.9	2.8	2.6	2.5	2.4	2.4	2.3
90	2.2	2.2	2.1	2.0	2.0	1.9	1.8	1.8	1.7	1.7	1.7	1.6