

## 1 Description

This product specification is applied to the Humidity Sensor Type HCZ – J3. The terminal electrode material uses Lead free solder (Sn/Ag/Cu ). This product is conformity with RoHS directive which means that lead, cadmium, mercury, hexavalent chromium and specific bromine-based flame retardants have not been used.

## 2 Applications

The applications of the component are used in relative humidity measurement, control and display. There are many end products can be used. For example air conditioner, humidifier, dehumidifier, hygrometer, recorder, transmitter...etc.

## 3 Model no. :

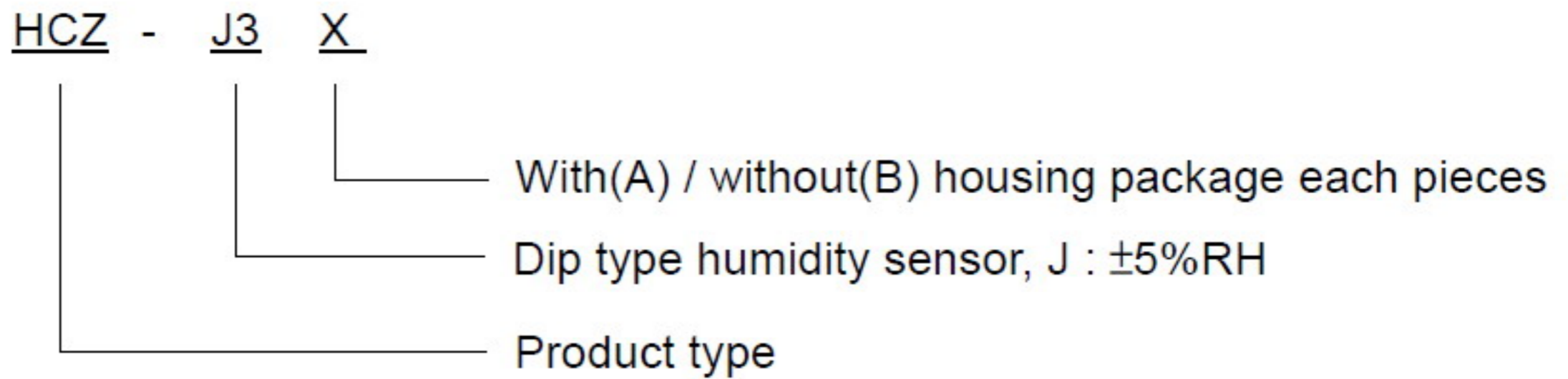

## 4 Configuration & Main parts :

### 4.1 Configuration : (Units : mm)

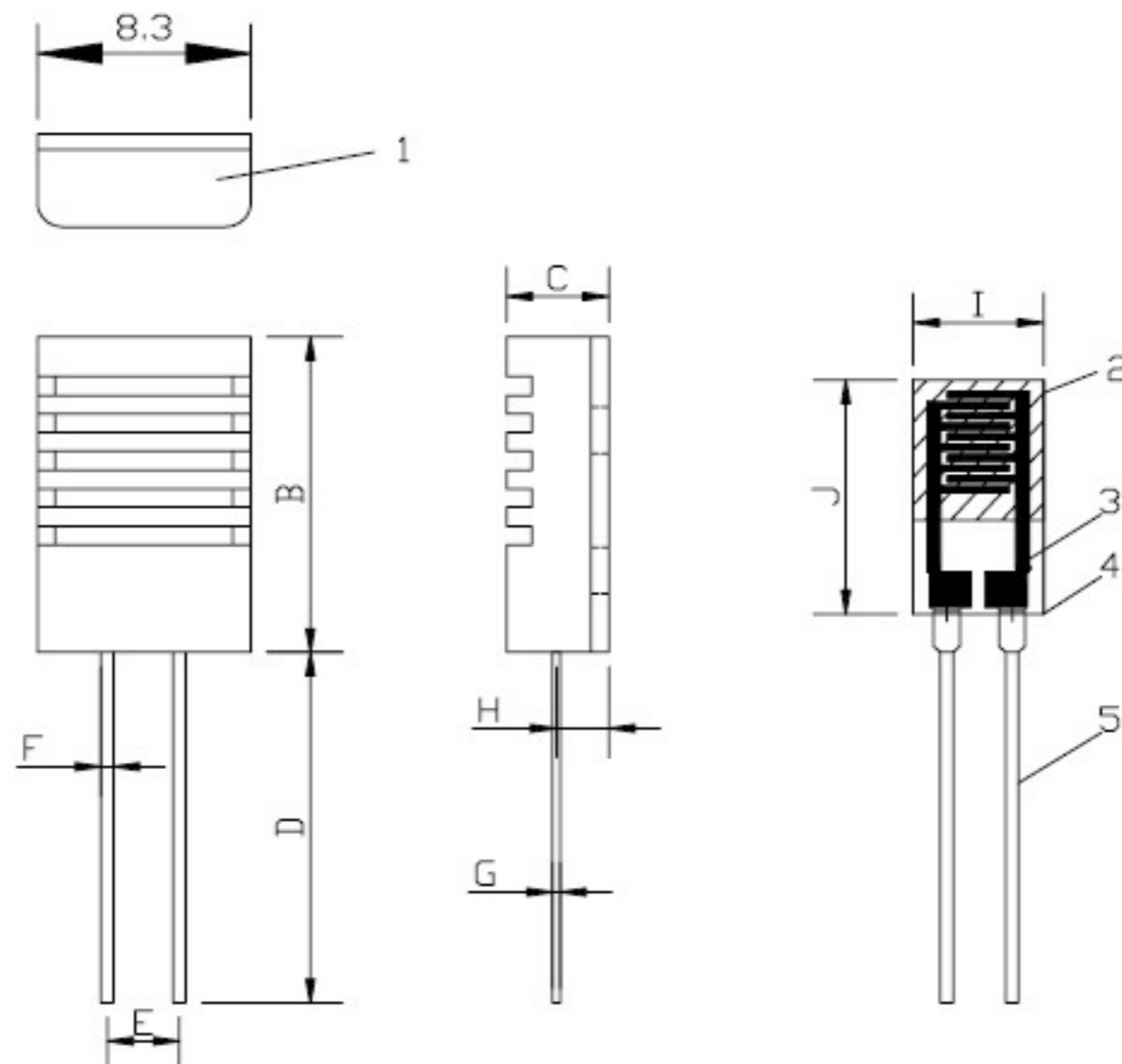

Units : mm

# PRODUCT SPECIFICATIONS

HCZ-J3

Symbol	Specifications	Symbol	Specifications
A	8.3±0.2	F	0.5±0.1
B	13.5±0.2	G	0.2±0.1
C	4.0±0.5	H	2.0±0.5
D	15±2	I	5.08±0.3
E	2.54±0.2	J	10±0.3

## 4.2 Main parts :

No.	Parts	Reference
1	Sensor case	PBT
2	Substrate	Alumina
3	Sensing material	Polymer
4	Electrode	Ag/Carbon
5	Lead frame	Phosphor bronze

## 5 Electrical characteristics :

### 5.1 General Characteristics :

	Units	Min.	Typ.	Max.
Rated voltage	Vrms	-	-	1
Rated power	mW	-	-	0.2
Operating frequency range	kHz	0.5	1	2
Operating temperature range	°C	0	-	60
Operating humidity range	%RH	-	-	90
Impedance range at 60%RH and 25°C**	kΩ	14.2	-	38.5
Humidity accuracy	%RH	-5	-	+5
Hysteresis (40%RH~80%RH)	%RH	-	-	2
Temperature dependence(reference)	%RH/°C	-	0.6	-

\*\* Measurement by LCR meter at 1KHz, 1 Vrms(sine wave)

### 5.2 Relative humidity - Impedance – 25°C, 1kHz, 1 Vrms(sine wave)

%RH	20	30	40	50	60	70	80	90
Normal value (kΩ)	5,000	920	220	66	23	9.0	4.2	1.9

### 5.3 Relative humidity - Impedance curve is shown in page 5

# PRODUCT SPECIFICATIONS

HCZ-J3

## 6 Mechanical characteristics :

No.	Item	Description	Criteria*
6.1	Shock resistance	Drop down 3 times@80cm	No abnormal appearance & electrical properties
6.2	Vibration resistance	2 hours each in the directions of X-Y-Z, at the frequency of 10-55Hz, and amplitude of 1.5mm	No abnormal appearance & electrical properties
6.3	Resistance to soldering heat	The lead terminal shall be Immersed by 3 mm from the substrate for 3 seconds in solder bath of $330\pm 5^{\circ}\text{C}$	No abnormal appearance & electrical properties
6.4	Strength of terminations	500g@10 seconds in the axial direction of lead terminal	Secured

## 7 Reliability :

No.	Item	Description	Criteria*
7.1	Heat resistance	1000 hours@ $70^{\circ}\text{C}$	$< \pm 5\% \text{RH}$
7.2	Cool resistance	1000 hours@ $-30^{\circ}\text{C}$	$< \pm 5\% \text{RH}$
7.3	Humidity resistance	1000 hours@ $60^{\circ}\text{C}$ , 90%RH	$< \pm 5\% \text{RH}$
7.4	Humidity cycle	Repeat 1000 cycles One cycle: 30 minutes@ $25^{\circ}\text{C}$ , $< 20\% \text{RH}$ 30 minutes@ $25^{\circ}\text{C}$ , $> 90\% \text{RH}$	$< \pm 5\% \text{RH}$
7.5	Temperature cycle	Repeat 100 cycles Each cycle: 30 minutes@ $-30^{\circ}\text{C}$ 30 minutes@ $85^{\circ}\text{C}$	$< \pm 5\% \text{RH}$
7.6	Voltage resistance	3000 hours@1KHz, 1Vrms	$< \pm 5\% \text{RH}$

\* The criteria test that the sensors finish the description process after over night under normal temperature and humidity. The test condition is fixed at  $25^{\circ}\text{C}$ , 60%RH by LCR meter at 1KHz, 1 Vrms(sine wave)

## 8 Packaging

### 8.1 HCZ-J3A

8.1.1 100 pieces of sensor to be packed in a bag.

8.1.2 In case of fractional package, the above bag and carton box may not be used.

### 8.2 HCZ-J3B

8.2.1 245 pieces were layed in tray, and 5 trays envelope in bag.

8.2.2 10,000 pieces packed in a shipping carton box (430\*360\*390mm).

8.2.3 In case of fractional package, the above tray and carton box may not be used.

### 8.3 Caution remarks on operation

8.3.1 To avoid direct application of DC voltage on humidity sensor.

8.3.2 To protect sensor from dewfall and drenching.

8.3.3 To avoid any operation of humidity sensors in the following environmental ambient.

8.3.3.1 Salt

8.3.3.2 Inorganic gas – Sulfide dioxide, Chlorine, Ammonia etc.

8.3.3.3 Organic gas – Alcoholic, Glycols, Aldehydes etc.

8.3.4 Recommended storage condition

Temperature range 10~40°C

Humidity range 90%RH or less

8.3.5 Do not store humidity sensors long period of time in an over 60°C ambient due to some occasion of degradation on sensor housing case.

# PRODUCT SPECIFICATIONS

HCZ-J3

● Impedance table -- %RH VS. Temperature

Unit:KΩ

RH%	5°C	10°C	15°C	20°C	25°C	30°C	35°C	40°C	45°C	50°C
20				7200	5000	3600	2500	1800	1300	1100
25	9900	6900	4600	3200	2300	1700	1100	920	600	520
30	4400	3100	2000	1500	920	770	530	430	280	250
35	1900	1400	900	670	450	360	250	210	140	114
40	810	600	430	310	220	170	130	96	74	61
45	420	300	220	160	120	90	71	55	43	35
50	211	150	110	83	66	51	40	31	25	20
55	109	83	62	48	37	29	23	19	15	13
60	63	48	37	29	23	18	15	12	10.3	8.7
65	37	28	22	18	14	12	10	8.1	6.9	5.9
70	22	17	14	12	9.6	8.0	6.8	5.8	4.9	4.3
75	14	12	9.4	7.8	6.5	5.5	4.7	4.1	3.4	3.0
80	9.0	7.3	6.0	5.0	4.2	3.8	3.3	2.9	2.4	2.0
85	6.0	4.8	3.9	3.3	2.8	2.5	2.2	2.0	1.7	1.4
90	4.0	3.2	2.7	2.2	1.9	1.7	1.5	1.4	1.2	1.1

● Impedance – Relative humidity curve

