

## PUSH BUTTON SWITCH WITH LED MLS SERIES



### Feature

- Small size
- LED illumination
- Two color available
- Single pole, Single throw

### Applications

- Computer Product
- Office appliance
- Communication Equipments

## SPECIFICATIONS

SWITCH SPECIFICATIONS	
POLE - POSITION	Momentary Type , SPST with LED
CONTACT RATING	36 V DC , 0.2 A
CONTACT RESISTANCE	40 mΩ max . 1.5 V DC ; 100 mA , by Method of Voltage DROP
INSULATION RESISTANCE	100 MΩ min . 500 V DC
DIELECTRIC STRENGTH	Breakdown is not Allowable ; 500 V AC for 1 Minute
OPERATING FORCE	300 ± 100 gf
OPERATING LIFE	10,000 cycles
OPERATING TEMPERATURE RANGE	-20°C ~ 70°C
TOTAL TRAVEL	FULL TRAVEL - 2.4 ± 0.3 mm CONTACT TRAVEL - 1.6 ± 0.3 mm

LED SPECIFICATIONS		Unit	Value / LED Color			
ATTENTION LEDs are Electrostatic Sensitive devices	Symbol		Blue	Green	Red	Yellow
		FORWARD CURRENT	If	mA	30	30
REVERSE VOLTAGE	Vr	V	5.0	5.0	5.0	5.0
REVERSE CURRENT	Ir	μA	50	10	10	10
FORWARD VOLTAGE@20mA	Vf	V	3.5-4.0	1.7-2.8	1.5-2.4	1.7-2.8
LUMINOUS INTENSITY@20mA	Iv	mcd	350-700	60-100	75-120	45-75

- Physical and electrical information of LED will be provided upon customer's request on switches.

## HOW TO ORDER

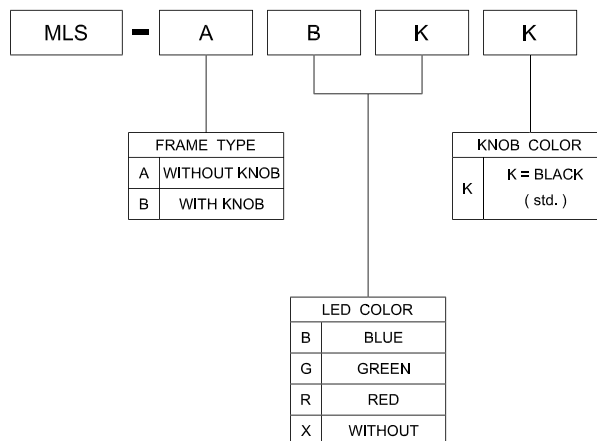

# HONEST-WELL CO.,LTD

## PUSH BUTTON SWITCH WITH LED MLS SERIES

### DIMENSION



MLS - A □ □

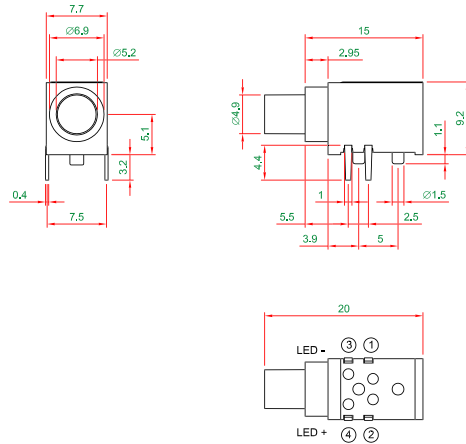

### DIMENSION



MLS - B □ □ K

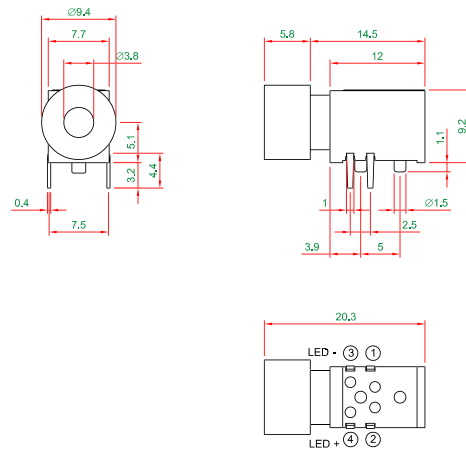

### SCHEMATIC

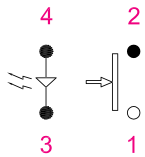

### P.C.B LAYOUT

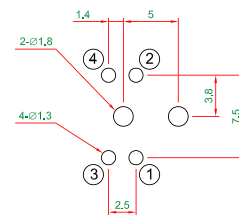

### MATERIAL

- COVER - PA + GF
- ACTUATOR - PA + GF
- BASE FRAME - PA + GF
- TERMINAL - BRASS SILVER PLATING

### UNIT WEIGHT

- MLS - A □ □ : 1.2 ± 0.05 g / pcs
- MLS - B □ □ K : 1.4 ± 0.05 g / pcs