

Float Level Sensor

● Float switch principle

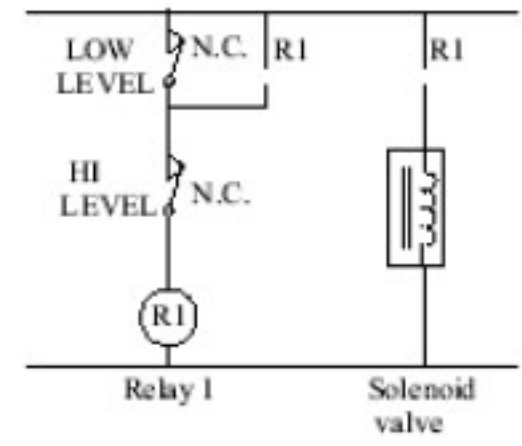
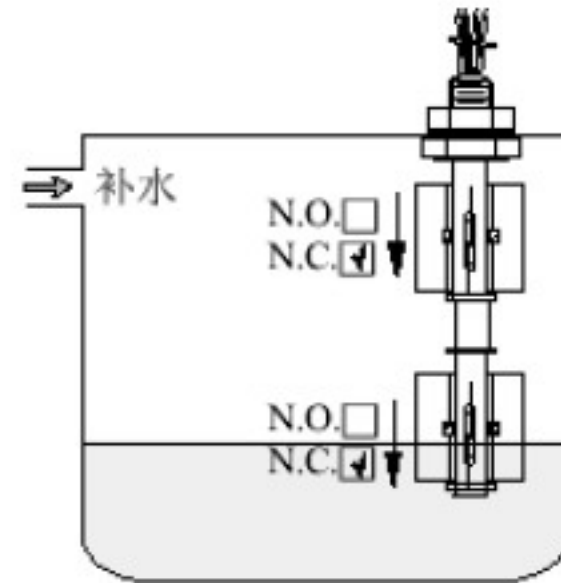
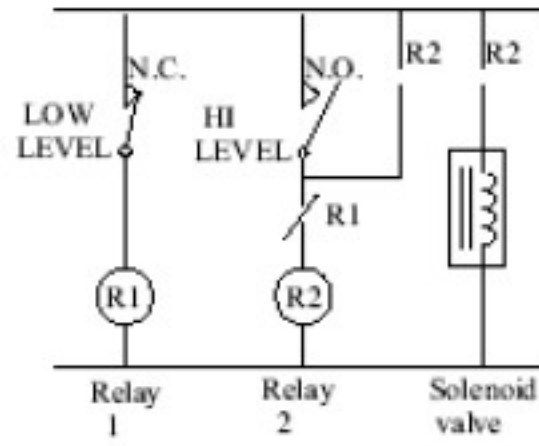
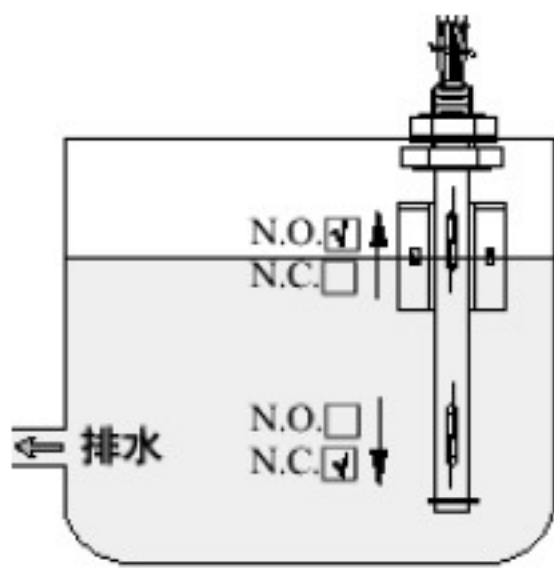

Float SW	Type	Size A×B×C (mm)	Material	Density g/cm ³	Temp. °C	Pressure Kg/cm ²
	S1	28×28×9.5	SUS316L	0.8	200	10
	S2	38×26.5×9.5	SUS316L	0.7	200	12
	S3	45×55×15	SUS316L	0.65	200	15
	S4	52×52×15	SUS316L	0.55	200	30
	S5	75×75×23	SUS304	0.7	200	64
	P1	25×25×10	PP	0.8	80	4
	P2	50×50×20	PP	0.8	80	4
	F1	75×75×23	PVDF	0.9	150	3